

Blast Chillers-Freezers CW

Blast Chiller-Freezer Crosswise - 12,5/7kg - (R452A)

ITEM # _____

MODEL # _____

NAME # _____

SIS # _____

AIA # _____

727901 (RBF051)

 Blast Chiller & Freezer
 12,5/7kg, compatible with
 5x1/1GN crosswise Oven -
 R452A

Short Form Specification

Item No.

- Blast chiller/freezer with digital temperature and time display
- For 6 GN 1/1 or 5 600x400 mm trays
- Load capacity: chilling 12,5 kg (UK guidelines); freezing 7 kg (UK guidelines)
- Single sensor core probe
- Operating air temperature: +3 -41°C
- Automatic and manual defrosting
- Blast chilling real residual time estimation (A.R.T.E.)
- Turbo cooling function
- Specific cycles for ice cream
- Evaporator with antitrust protection
- HACCP and Service alarms with data logging
- Main components in 304 AISI stainless steel
- Internal rounded corners and drain
- Cyclopentane insulation (HCFC, CFC and HFC free)
- Built-in refrigeration unit
- R452a refrigerant gas (HCFC and CFC free)
- Performance guaranteed at ambient temperatures of 40°C

Main Features

- Blast Chilling cycle: 12,5 kg from 90°C up to 3°C in less than 90 minutes.
- Blast Freezing cycle: 15 kg from 90°C up to -18°C in less than 240 min.
- Soft Chilling (air temperature -2°C).
- Hard Chilling (air temperature -20°C).
- Freezing (air temperature -36°C)
- Remaining time estimation for probe-driven cycles based on artificial intelligence techniques (ARTE) for an easier planning of the activities.
- Single sensor core probe as standard.
- Control unit provides two large displays to read out: time, core temperature, cycle countdown, alarms, service information.
- All information related to the different operating models are recorded: date, time, cycle, core temperature, holding temperature, HACCP accordance.
- Two customizable cycles (P1 & P2) for each operating mode, allowing to set the time and air temperature. These programs can be converted into ice-cream specialized cycles (shape maintenance and holding).
- Turbo cooling: chiller works continuously at the desired temperature; ideal for continuous production.
- Performance guaranteed at ambient temperatures of +40°C.
- Holding at +3 °C for chilling or -18 °C for freezing, automatically activated at the end of each cycle, to save energy and maintain the target temperature (manual activation is also possible).
- Automatic and manual defrosting.

Construction

- No water connections required.
- High density polyurethane insulation, 60 mm thickness, HCFC free.
- Ventilator swinging hinged panel for access to the evaporator for cleaning.
- Waste water can be plumbed into drain, but can also be collected in an optional waste container.
- Environmentally friendly: R452a as refrigerant gas.
- Built-in refrigeration unit.
- Removable magnetic door gasket with hygienic design.
- 6 levels available. Usable with 5 GN 1/1 or 600x400 mm trays.

APPROVAL: _____

Included Accessories

- 1 of 1 single-sensor probe for blast chiller and blast chiller&freezers PNC 880213

Optional Accessories

- Connectivity kit for AOC/EasyLine and CW Blast Chillers/Blast Chiller Freezers (ECAP) PNC 880183
- 1 single-sensor probe for blast chiller and blast chiller&freezers PNC 880213
- 4 feet for undercounter blast chillers/blast chiller freezers for 726658 and 726659 PNC 880338
- Rilsan grid 600x400mm PNC 880864
- Plastic coated grid, 1/1GN PNC 881061
- Pair of 1/1GN AISI 304 stainless steel grids PNC 921101
- KIT HACCP EKIS PNC 922166
- Ethernet connector for ECAP protocol appliances PNC 922768

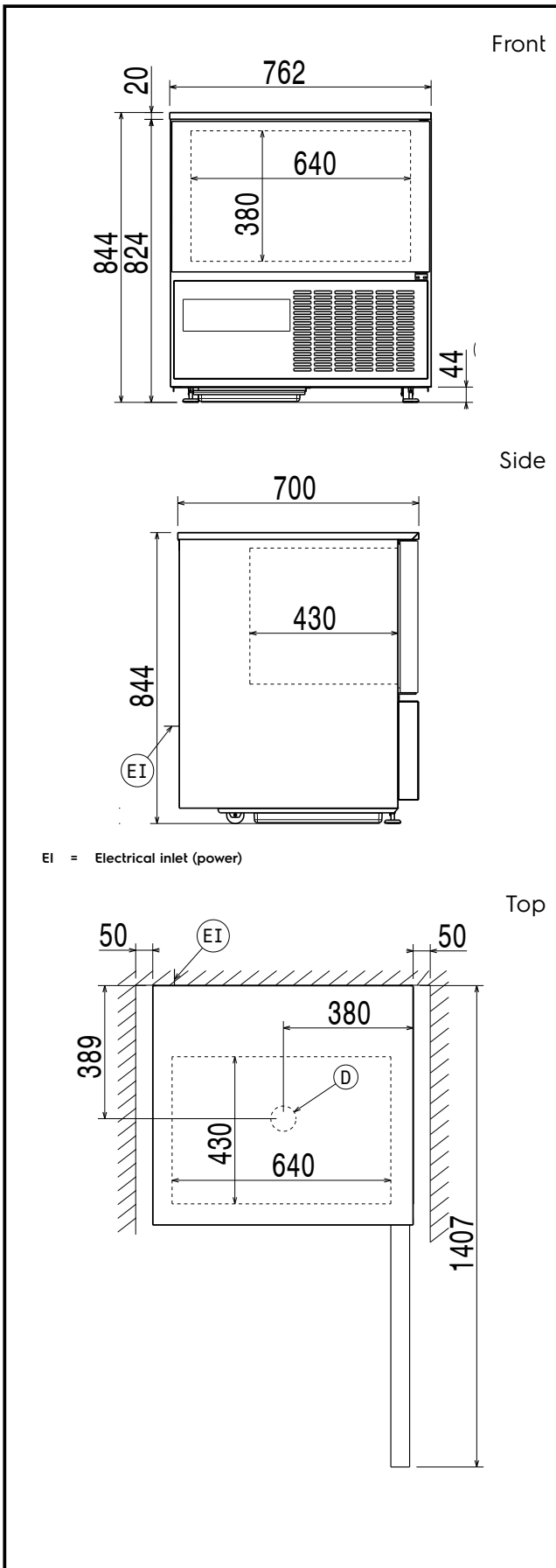

Electric

Supply voltage:
 727901 (RBF051) 230 V/1 ph/50 Hz
 Electrical power max.: 0.73 kW
 Circuit breaker required

Installation:

Clearance: 5 cm on sides and back.
 Please see and follow detailed installation instructions provided with the unit

Capacity:

GN: 5 - 1/1 containers

Key Information:

External dimensions, Width: 762 mm
 External dimensions, Depth: 700 mm
 External dimensions, Height: 844 mm
 Net weight: 95 kg
 Shipping weight: 97 kg
 Shipping volume: 0.69 m³

Refrigeration Data

Refrigeration power at evaporation temperature: -23.3 °C

Product Information (EN17032 - Commission Regulation EU 2015/1095)

Chilling Cycle Time (+65°C to +10°C): 113 min
 Full load capacity (chilling): 15 kg
 Freezing Cycle Time (+65°C to -18°C): 250 min
 Full load capacity (freezing): 5 kg

Sustainability

Refrigerant type: R452A
 GWP Index: 2141
 Refrigeration power: 234 W
 Refrigerant weight: 460 g
 Energy consumption, cycle (chilling): 0.094 kWh/kg
 Energy consumption, cycle (freezing): 0.507 kWh/kg